



Illustration similar

TORQUE AND FEED FORCE MEASURING TRANSDUCER FOR CONTACT-FREE TOOL MONITORING

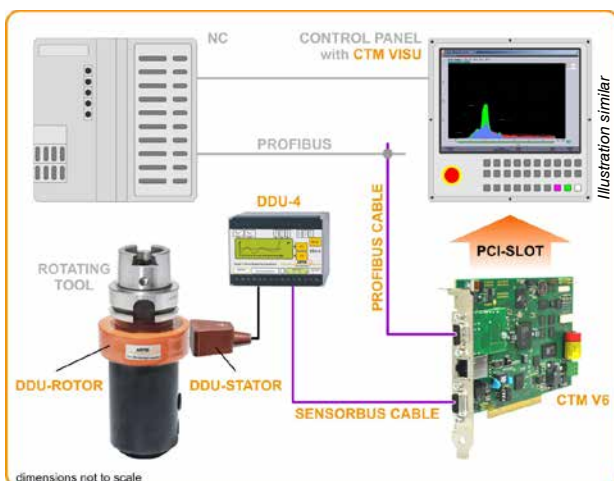

Illustration similar

Special Features

- Component of the CTM monitoring system
- Also applicable as autonomous system for stand-alone solutions
- Measuring transducer for connecting the DDU sensor system
- Supply voltage 24 V DC

Application

The DDU-4 Measuring Transducer is applied for measuring torque and feed forces of rotating and rigid tools.

Contact-free monitoring is the distinctive feature of this method. For this reason, the system is frequently employed for monitoring drilling and tapping processes. However, it is also suitable for monitoring non-rotating tools.

Application example:

DDU-4 measuring transducer in combination with the CTM V6 Tool and Process Monitoring System and the DDU sensor system for measuring torque and feed forces.

Torque and Feed Force Measuring Transducer

DDU-4

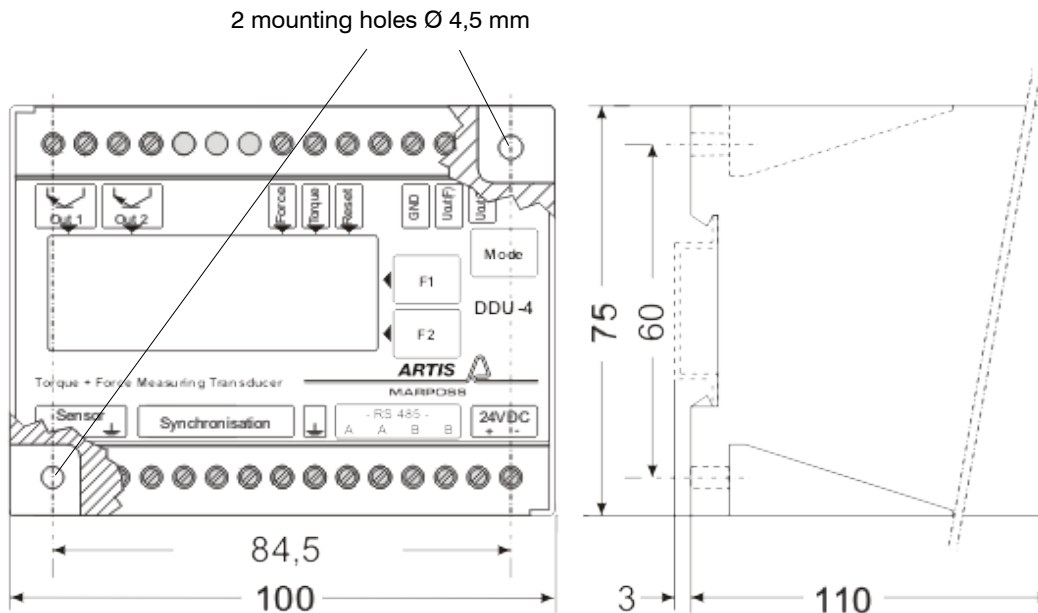

DDU-4 O830Z311001	
Dimensions	see drawing
Weight	0.415 kg
Material	Makrolon
Degree of protection	IP20
Contacting	Screw terminals
Operating temperature	0 – 50 °C
Rel. humidity	5 – 85 % without condensation
Mounting	<ul style="list-style-type: none"> Standard mounting rail acc. to DIN EN 60715 Screw connection
Voltage supply	24 V DC (18 – 36 V), stabilized, max. 5 % ripple
Nominal current consumption	max. 400 mA
Interface	ARTIS sensor bus ASB (RS485)
Data output	in single-spindle operation mode via RS485 at 10 ms-rate, format ASCII for feed and torque

Measuring ranges	3 ranges each, for torque and feed force	
Control inputs	T = Torque activation 18 – 36 V DC F = Force activation 18 – 36 V D Reset 18 – 36 V DC	
Switching outputs	Out1 F = Force	Breakage alarm
	Out2 T = Torque	Breakage alarm
Analog output	±10 V, torque and feed force separately	
Operation		
within CTM system	via operation panel of the NC control using the ARTIS CTM menu	
as stand-alone device	using 3 membrane keys and the illuminated, graphics capable LCD display	
Conformity	CE	



www.marposs.com

For a full list of address locations, please consult the Marposs official website

ODN6420EN07 – Edition 11/2017 – Specifications are subject to modifications
© Copyright 2017 MARPOSS Monitoring Solutions GmbH (Germany) – All rights reserved.

ARTIS and Marposs product names/signs mentioned or shown herein are registered trademarks or trademarks of Marposs in the United States and other countries. The rights, if any, of third parties on trademarks or registered trademarks mentioned in the present publication are acknowledged to the respective owners.

Marposs has an integrated system to manage the Company quality, the environment and safety, attested by ISO 9001, ISO 14001 and OHSAS 18001 certifications. Marposs has further been qualified EAQF 94 and has obtained the Q1 Award.



Download the latest version of this document